

## USER MANUAL

### Green Pin® Open Long Wedge Sockets

Material : high tensile steel

Finish : hot dipped  
galvanized

The wedge and body act as a vice which grips the wire rope and locks it in place. Green Pin® wedge sockets may be used within the range of wire rope diameters as shown in the table in the catalogue.

When using open wedge sockets the following precautions should be taken:

- before use always inspect the socket, the wedge and the pin;
- use only with standard 6-8 strand wire rope;
- in case of use with non-rotating wire rope there is a risk of core slippage or loss of rope lay. Instruction from the wire rope manufacturer must be followed to prevent this by; for example welding, brazing or seizing the dead end before introduction in the socket. The minimum tail length is 20 times the wire rope diameter. Furthermore, the wire rope construction must be checked for suitability of bending around the radius of the wedge. Additional measures might be necessary to prevent distortion.
- Verify whether the wedge, socket and wire rope clip match to the wire rope size. In case of the long wedge sockets (G-6419 and G-6429) the correct wire rope size shall be verified using the “GO” and “NO GO” hole (see Figure 1);
  - The wire rope MUST pass through the “GO” hole in the wedge;
  - The wire rope shall NOT pass through the “NO-GO” hole in the wedge;

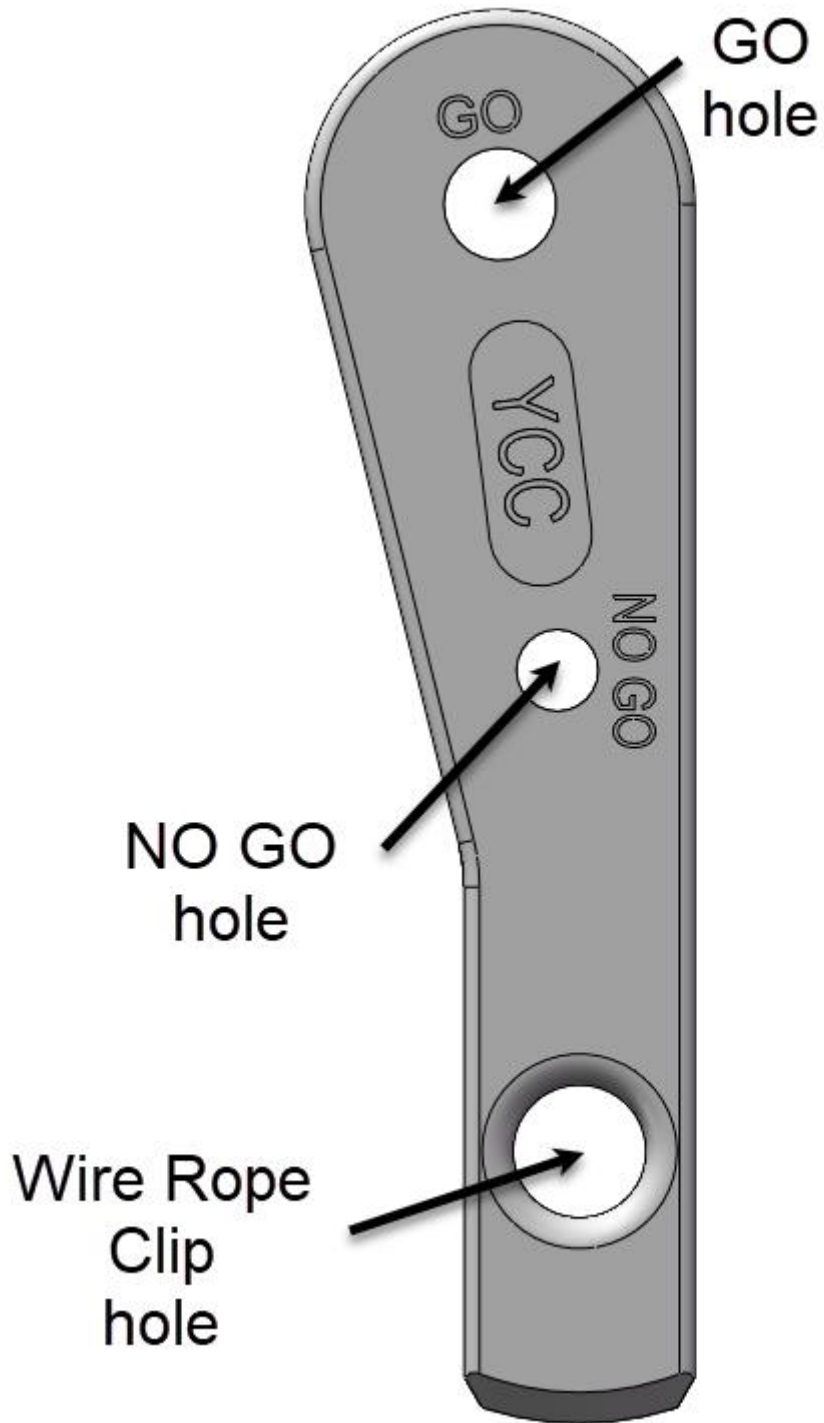

Figure 1

- In case of the long wedge sockets (G-6419 and G-6429) mount the corresponding Wire Rope Clip (G-6240) on the dead end section, providing a grip for the tail of the wire rope (see Figure 2 below). The tail length of the wire rope has to be at least 6 times the wire rope diameter with a minimum of 150 mm.

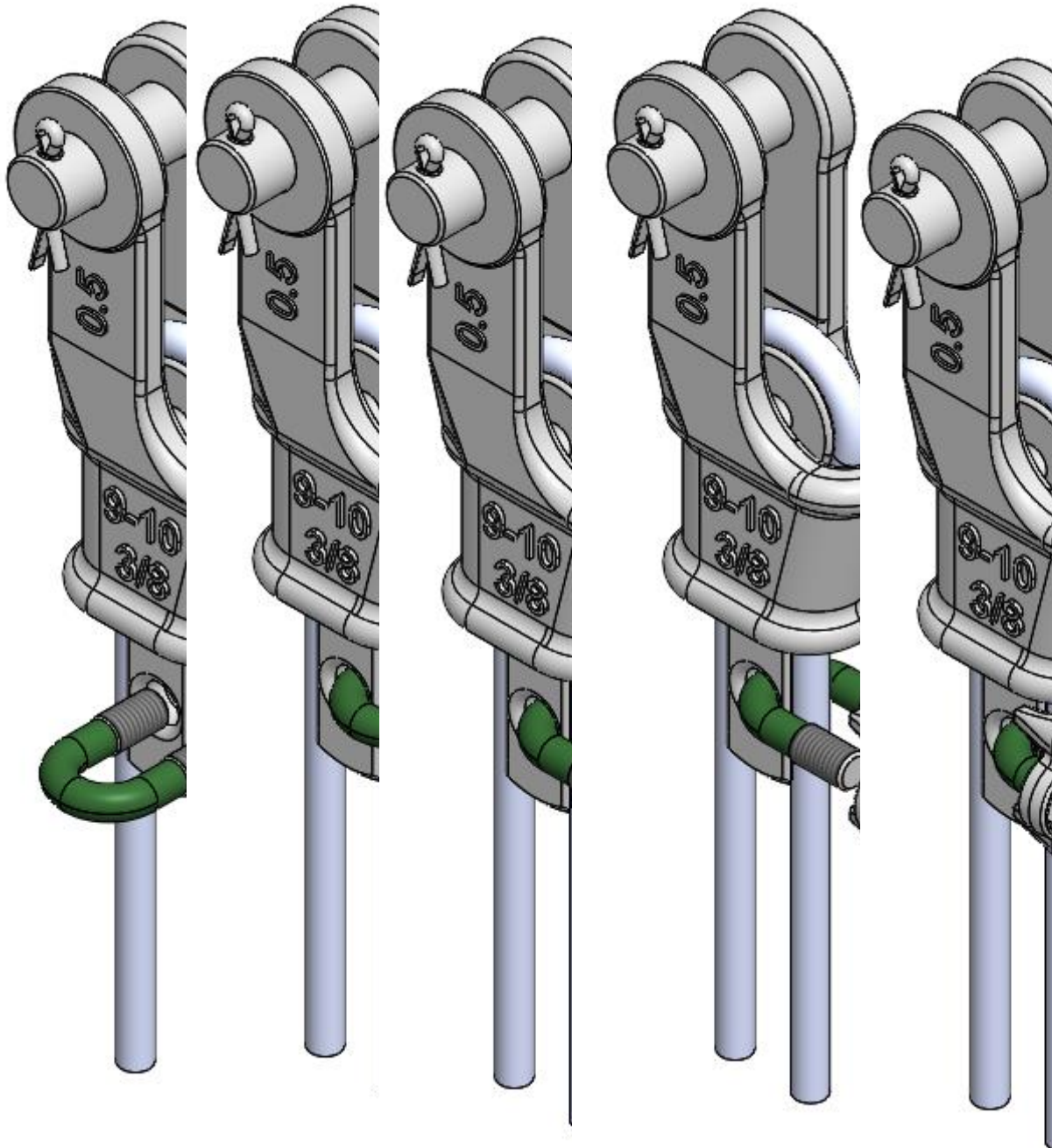
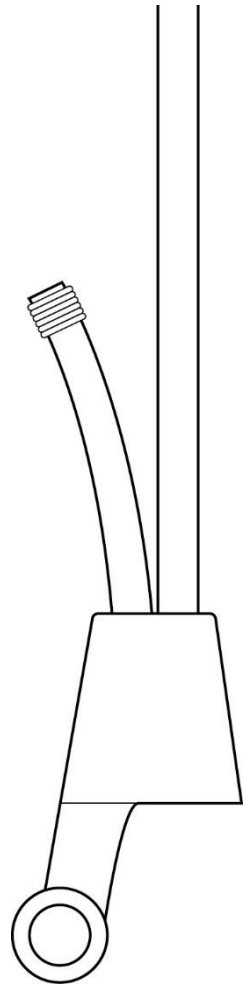
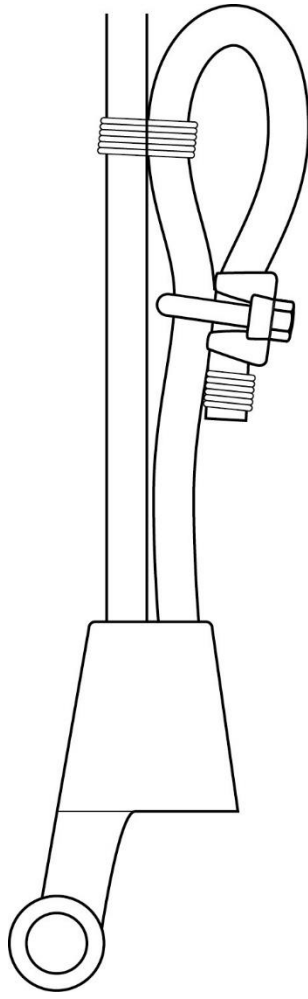
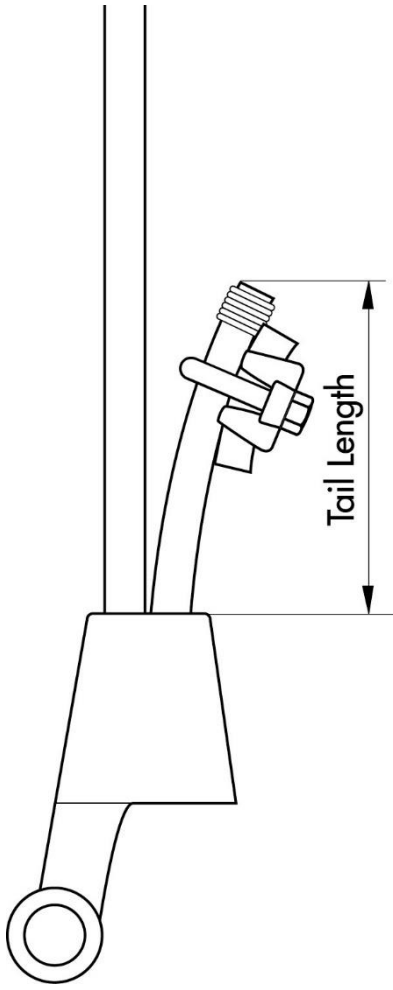
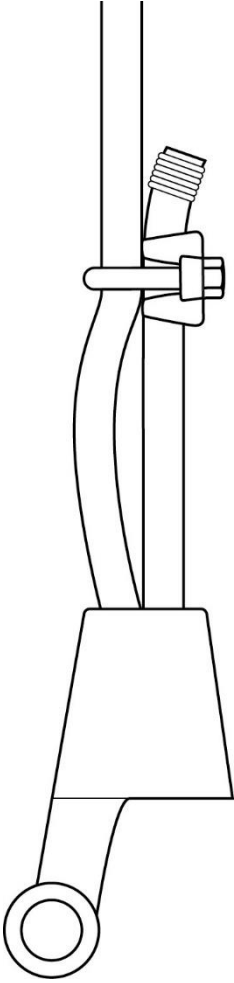

Figure 2

- the loaded part of the steel wire rope should be mounted in the center line of the pin;
- when installing the wire rope, always pre-load the wedge with the wire rope in place;
- never weld the tail; the tail should have a length of at least 6 times the wire rope diameter with a minimum of 150 mm. Secure the dead end of the rope with a wire rope clip as shown in figure 3;
- before applying the first load always use a hammer to seat the wedge and rope into the socket as deep as possible;
- check the assembly regularly; re-tighten or re-position if necessary;
- never side load a wedge socket as it has not been designed for that purpose;
- load may slip if the connection is not properly installed;
- breaking load of the wire, but is limited to the minimum breaking load of the socket;
- only use the original wedge supplied by the manufacturer of the socket and be sure it is suitable for the diameter of the rope used;
- never use a wedge from any other supplier than the original socket supplier as the dimensions will not match;





It is required that the products are regularly inspected and that the inspection should take place in accordance with the safety standards given in the country of use. This is required because the products in use may be affected by wear, misuse, overloading etc. with a consequence of deformation and alteration of the material structure. Inspection should take place at least every six months and even more frequently when the sockets are used in severe operating conditions.